

Technical features

Power supply

Three-phase voltage from 24V to 690V, 50Hz or 60Hz or single-phase 100-130V, 60Hz and 200-240V, 50Hz; suitable for use with an inverter from 20Hz to the base frequency with constant torque load profile.

Polarity

2 and 4 poles.

Conformity with Standards and Regulations

Low Voltage Directive 2006/95/EC; ATEX Directive 2014/34/UE; EN/IEC 60034-1, EN/IEC 60079-0, EN/IEC 60079-31, UL 1004-1, CSA C22.2 No.100, NEMA MG-1.

Functioning

Continual service (S1) at maximum declared centrifugal force and electric power. Intermittent services are also possible depending on the type of vibrator and the operating conditions. For detailed information contact our technical assistance office.

Centrifugal force

Range up to 311 kgf (3.05 kN). Centrifugal force can be changed by adjusting the eccentric weights

Mechanical protection

IP 66 according to IEC/EN 60529.

Protection against mechanical impacts

IK 08 according to IEC/EN 62262.

Insulation class

Class F (155°C).

Tropicalization

Standard with vacuum encapsulation.

Ambient temperature

From -20°C to +40°C.

Vibrator thermal protection

On request with PTC thermistor rated heat detectors 130°C.

Fixing of the vibrator

In all positions and therefore without restriction.

Lubrication

Sealed ball bearings, lubricated "for life".

Terminal box

The terminal box is positioned underneath the vibrator, on the same side as the fixing base. Special shaped terminals allow to fix the power supply cable, protecting it from loosening.

Electric motor

Three-phase or single-phase asynchronous type. Insulated windings using vacuum encapsulating. The rotor is die cast aluminium.

Casing

In high-tensile aluminium alloy, with sand blasted surface. Multiholes fixing base allow different fixing patterns.

Designed for industrial continuous duty, the M3 series features a compact shape, reduced overall dimensions, terminal box underneath which means also a high electric protection in dusty environments. Multi-holes mounting feet enable M3 series to match several existing mounting plates. M3 series motors comply with the most recent international standards for use in explosive dust atmospheres. Particularly M3 series can be used in zones 21 and 22.

Category: II 2 D

Level of protection:

Ex tD A21 T...°C IP66 (Ex tb IIIC T...°C Db)

Temperature class:

T120°C

Zones of use:

21, 22

Bearing flange

In ductile cast iron.

The geometry of the flange transmits the load to the casing uniformly.

Motor shaft

In treated steel alloy (Isothermic hardening) resistant to stress.

Eccentric weights

Easily adjustable from 100% down to 0.

Weight covers

Made in die cast, high strength aluminium alloy with accurate surface sand blasting.

For further details please contact sales offices at Italtvibras.

The technical data and models listed in this catalogue are not binding. Italtvibras reserves the right to modify them without prior notice.

Certifications



Compliance with the applicable European Union directives.



Standard CAN/CSA – C22.2, N°.100-95,
Certificate n° LR 100948
Class 4211 01 - Motors e generators
UL 1004-1 – Rotating Electrical Machines –
General Requirements
Class II Div.2, Groups FG (T3B)



II2D (2014/34/UE)
Ex tD A21 T...°C IP66 (Ex tb IIIC T...°C Db)
EN 60079-0
EN 60079-31



Ex tD A21 T...°C IP66 (Ex tb IIIC T...°C Db)
IEC 60079-0
IEC 60079-31



Certification for Eurasian Customs Union
N° TC N RU Д-IT.АЛ33.В.02527
N° TC RU C-IT.Г508.В.02190



KOSHA Korea
Certificate n° 11-AVG BO-0359
Ex td A21 IP66

M3



2 poles - 3.000/3.600 rpm

Three-phase

DESCRIPTION				MECHANICAL SPECIFICATIONS								ELECTRICAL SPECIFICATIONS					
Code	Type	SIZE	II2D Temp. class	Static moment* kgmm		Centrifugal force				Weight kg		Max input power W		Max. current A		Ia/In	
				50Hz	60Hz	50Hz	60Hz	50Hz	60Hz	50Hz	60Hz	50Hz	60Hz	400V 50Hz	460V 60Hz	50Hz	60Hz
600467	M3/65-S02	00	• 120°C	6,43	6,43	64,7	93,1	0,635	0,913	4,30	4,30	120	120	0,27	0,23	3,43	3,90
600465	M3/105-S02	00	• 120°C	9,64	9,64	97	140	0,95	1,37	5,20	5,20	180	180	0,35	0,30	2,68	3,00
600462	M3/205-S02	00	• 120°C	20,2	20,2	203	293	2,00	2,87	6,00	6,00	180	180	0,35	0,30	2,68	3,00
600461	M3/305-S02	00	• 120°C	29,8	20,2	300	293	2,94	2,87	6,30	6,00	180	180	0,35	0,30	2,68	3,00

Single-phase

Code	Type	SIZE	II2D Temp. class	Static moment* kgmm		Centrifugal force				Weight kg		Max input power W		Max. current A		Ia/In	
				50Hz	60Hz	50Hz	60Hz	50Hz	60Hz	50Hz	60Hz	50Hz	60Hz	400V 50Hz	460V 60Hz	50Hz	60Hz
600467	M3/65-S02	00	• 120°C	6,43	6,43	64,7	93,1	0,635	0,913	4,30	4,30	110	110	0,56	1,52	2,24	2,24
600465	M3/105-S02	00	• 120°C	9,64	9,64	97	140	0,95	1,37	5,20	5,20	165	165	0,75	1,52	1,67	2,24
600462	M3/205-S02	00	• 120°C	20,2	20,2	203	293	2,00	2,87	6,00	6,00	165	165	0,75	1,52	1,67	2,24
600461	M3/305-S02	00	• 120°C	29,8	20,2	300	293	2,94	2,87	6,30	6,00	165	165	0,75	1,52	1,67	2,24

4 poles - 1.500/1.800 rpm

Three-phase

DESCRIPTION				MECHANICAL SPECIFICATIONS								ELECTRICAL SPECIFICATIONS					
Code	Type	SIZE	II2D Temp. class	Static moment* kgmm		Centrifugal force				Weight kg		Max input power W		Max. current A		Ia/In	
				50Hz	60Hz	50Hz	60Hz	50Hz	60Hz	50Hz	60Hz	50Hz	60Hz	400V 50Hz	460V 60Hz	50Hz	60Hz
601514	M15/36-S02	00	• 120°C	12,1	12,1	30,5	43,8	0,30	0,43	5,40	5,40	85	95	0,21	0,20	1,78	1,95
601515	M15/81-S02	00	• 120°C	29,8	20,2	75,0	73,0	0,74	0,72	6,30	6,0	85	95	0,21	0,20	1,78	1,95

Single-phase

Code	Type	SIZE	II2D Temp. class	Static moment* kgmm		Centrifugal force				Weight kg		Max input power W		Max. current A		Ia/In	
				50Hz	60Hz	50Hz	60Hz	50Hz	60Hz	50Hz	60Hz	50Hz	60Hz	400V 50Hz	460V 60Hz	50Hz	60Hz
601514	M15/36-S02	00	• 120°C	12,1	12,1	30,5	43,8	0,30	0,43	5,40	5,40	90	100	0,43	1,00	1,20	1,30
601515	M15/81-S02	00	• 120°C	29,8	20,2	75,0	73,0	0,74	0,72	6,30	6,0	90	100	0,43	1,00	1,20	1,30

* Working moment = 2 x static moment. Ia/In = rapporto fra corrente di avviamento e corrente max.

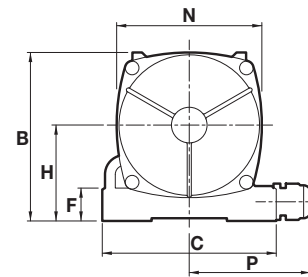
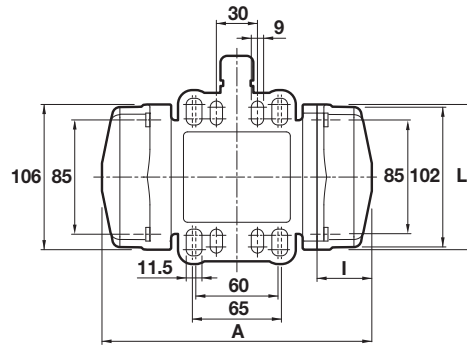

Fig. M1

DIMENSIONAL SPECIFICATIONS (mm)

Type	Fig.	A	B	C	Multi-hole		Holes		F	H	I	ØL	M	N	P	Capacitor (µF)		Cable entry thread
					D	E	ØG	N°								220V 50Hz	115V 60Hz	
M3/65-S02	M1	197									40							
M3/105-S02	M1	211	123	127	See drawing		9	4	24	70	47	106	86	106	88,5	-	-	M20x1,5
M3/205-S02	M1	235									59							
M3/305-S02	M1	235									59							

Type	Fig.	A	B	C	Multi-hole		Holes		F	H	I	ØL	M	N	P	Capacitor (µF)		Cable entry thread
					D	E	ØG	N°								220V 50Hz	115V 60Hz	
M3/65-S02	M1	197									40							
M3/105-S02	M1	211	123	127	See drawing		9	4	24	70	47	106	86	106	88,5	10	28	M20x1,5
M3/205-S02	M1	235									59							
M3/305-S02	M1	235									59							

DIMENSIONAL SPECIFICATIONS (mm)

Type	Fig.	A	B	C	Multi-hole		Holes		F	H	I	ØL	M	N	P	Capacitor (µF)		Cable entry thread
					D	E	ØG	N°								220V 50Hz	115V 60Hz	
M15/36-S02	M1	214	123	127	See drawing		9	4	24	70	59	106	86	106	88,5	-	-	M20X1,5
M15/81-S02	M1	235																

Type	Fig.	A	B	C	Multi-hole		Holes		F	H	I	ØL	M	N	P	Capacitor (µF)		Cable entry thread
					D	E	ØG	N°								220V 50Hz	115V 60Hz	
M15/36-S02	M1	214	123	127	See drawing		9	4	24	70	59	106	86	106	88,5	3,15	25	M20X1,5
M15/81-S02	M1	235																

M3-E

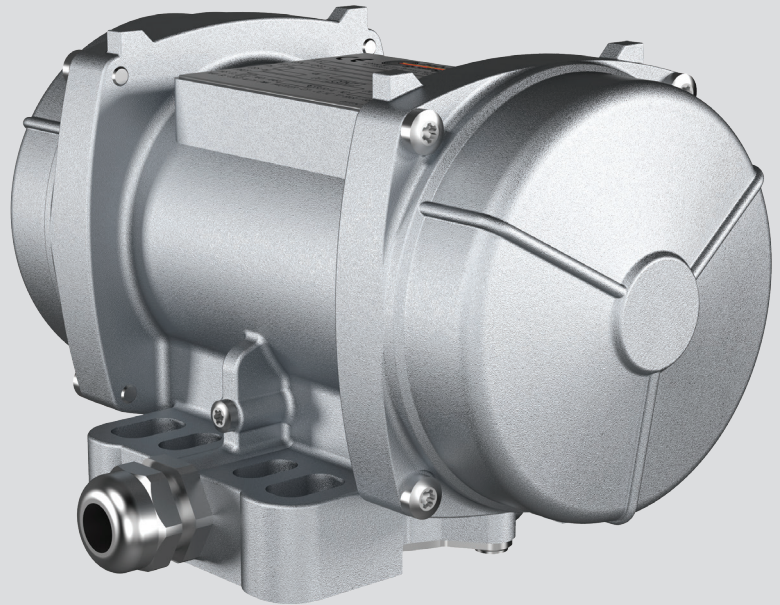

Technical features

Power supply

Three-phase voltage 127/220V 50Hz, 200/346V 50Hz, or 210/363V 60 Hz; variable frequency (in presence of PTC thermistor) from 20Hz to the base frequency with constant torque load profile.

Polarity

2 poles.

Conformity with Standards and Regulations

ATEX Directive 2014/34/UE;
EN/IEC 60079-0, EN/IEC 60079-7,
EN/IEC 60079-31, EN/IEC 60034-1.

Controls

The components that affect protection are 100% accurately controlled and recorded.

Functioning

Continual service (S1) at maximum declared centrifugal force and electric power.

Centrifugal force

Range up to 311 kgf (3.05 kN). Centrifugal force can be changed by adjusting the eccentric weights.

Mechanical protection

IP 66 according to IEC/EN 60529.

Protection against mechanical impacts

IK 08 according to IEC/EN 62262.

Insulation class

Class F (155°C).

Tropicalization

Standard with vacuum encapsulation.

Ambient temperature

From -20°C to +40°C, on request it is possible to have vibrators for max. ambient temperatures of +55°C.

Vibrator thermal protection

On request with PTC thermistor rated heat detectors 130°C.

Fixing of the vibrator

In all positions and therefore without restriction. The terminal box is positioned underneath the vibrator, on the same side as the fixing base.

Lubrication

Sealed ball bearing, lubricated "for life".

Terminal box

The terminal box is positioned underneath the vibrator, on the same side as the fixing base. Special shaped terminals allow to fix the power supply cable, protecting it from loosening.

Electric motor

Three-phase asynchronous type. Insulated windings using vacuum encapsulating. The rotor is die cast aluminium.

Casing

In high-tensile aluminium alloy, with sand-blasted surface. Multiholes fixing base allow different fixing patterns.

2 poles - 3.000/3.600 rpm

Three-phase

DESCRIPTION			MECHANICAL SPECIFICATIONS								ELECTRICAL SPECIFICATIONS									
Code	Type	SIZE	Static moment* kgmm		Centrifugal force kg kN				Peso kg		Temp class (G)	Temp class (D)	Max input power W		Power rating W		Max. current A		tE (s)	Ia/In
			50Hz	60Hz	50Hz	60Hz	50Hz	60Hz	50Hz	60Hz			50Hz	60Hz	50Hz	60Hz	400V 50Hz	460V 60Hz		
6E0467	M3/65E-S02	00	6,43	6,43	64,7	93,1	0,635	0,913	4,30	4,30	T4	120°C	105	105	80	80	0,30	0,29	20	3,48
6E0465	M3/105E-S02	00	9,64	9,64	97,0	140	0,95	1,37	5,20	5,20										3,68
6E0462	M3/205E-S02	00	20,2	20,2	203	293	2,00	2,87	6,00	6,00										3,68
6E0461	M3/305E-S02	00	29,8	20,2	300	293	2,94	2,87	6,30	6,00										3,68

* Working moment = 2 x static moment.

tE (s) = set time tE from IEC/EN 60079-7.

The M3-E is designed for use in industrial processes in environments with a potentially explosive atmosphere, caused by gas and dust, in compliance with ATEX Directive (94/9/EC).

In particular, the M3-E can be used in areas 1 and 2 (gas) and in areas 21 and 22 (dusts) according to the layout and the following features:

Category: II2D & II2G

Level of protection:

Ex tb IIIC T120°C Db, Ex e IIC T4 Gb

Temperature class:

Gas T4 (135°C)

Powders:

T120°C

Zones of use:

1, 2, 21, 22

Bearing flange

In ductile cast iron. The geometry of the flange transmits the load to the casing uniformly.

Motor shaft

In treated steel alloy (Isothermic hardening) resistant to stress.

Eccentric weights

Easily adjustable from 100% down to 0.

Weight covers

Made in die cast, high strength aluminum alloy with accurate surface sand blasting.

Other features

For the M3-E series, the user must fill the terminal box with suitable silicone, after having performed the connection.

Certifications



Compliance with the applicable European Union directives.



Ex tb IIIC T120°C Db
IEC 60079-0
IEC 60079-31



II2G II2D (2014/34/UE)
Ex e IIC T4 Gb
Ex tb IIIC T120°C Db
EN 60079-0
EN 60079-7
EN 60079-31



Certification for Eurasian Customs Union
N° TC RU C-IT.ГБ08.В.02190



KOSHA Korea
Certificate n° 11-AVG BO-0346/7/8/9/50/51
Ex e IIT3/T4
Ex td A21 IP66

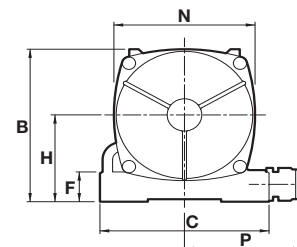
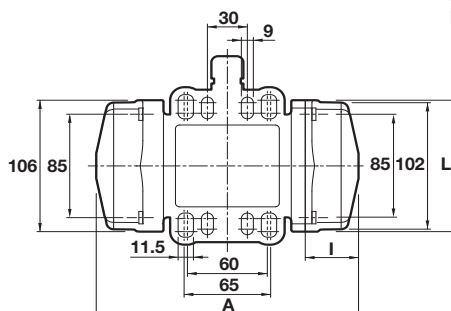

Fig. M1

DIMENSIONAL SPECIFICATIONS (mm)

Type	Fig.	Multi-hole			Holes		ØG	N°	F	H	I	L	M	N	P	Cable entry thread
		A	B	C	D	E										
M3/65E-S02	M1	197									40					
M3/105E-S02	M1	211									47					
M3/205E-S02	M1	235	123	127	See drawing		9	4	24	70	59	106	86	106	88,5	M20x1,5
M3/305E-S02	M1	235									59					

la/ln = rapporto fra corrente di avviamento e corrente max.