

GT/RF STAINLESS STEEL PNEUMATIC TURBINE VIBRATORS (European Specification*)

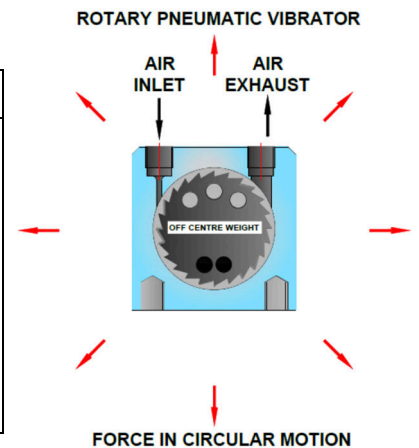

Stainless Steel
Rotary Vibrator
No Lubrication
Force 583 N to 4900 N
Suitable for temperature up to -40°C to 120°C
Noise level 60-70 dB(a) with silencer fitted

On request can be supplied with ATEX certification to ATEX 95 94/9/EC  II 2 G & D Zone 1, 2 & 21, 22

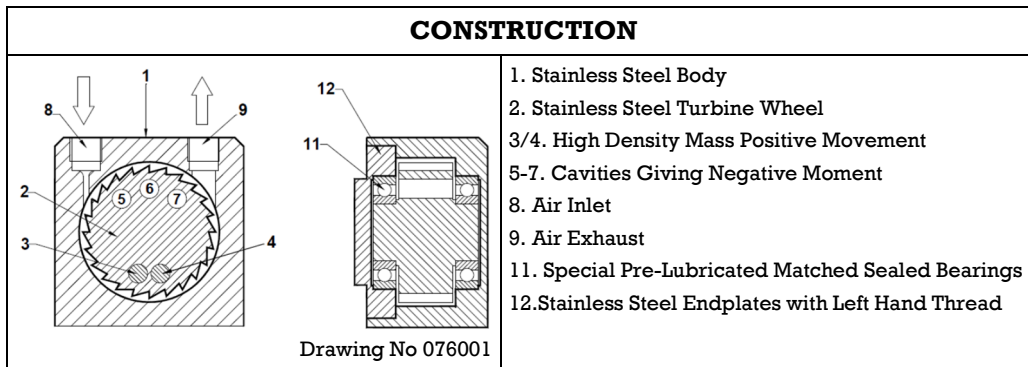

PERFORMANCE DATA

Models		Frequency V.P.M.			Centrifugal Force						Air Consumption / Minute					
		2 Bar	4 Bar	6 Bar	2 Bar	29 PSI	4 Bar	58 PSI	6 Bar	87 PSI	2 Bar	29 PSI	4 Bar	58 PSI	6 Bar	87 PSI
Standard	ATEX	29 PSI	58 PSI	87 PSI	N	lbs	N	lbs	N	lbs	Litr	CF	Litr	CF	Litr	CF

GTRF available to special order only- no Mounting Plate

GT10RF	GT10RF EX	27500	35000	37500	583	131	946	212	1086	243	46	1.6	80	2.8	112	3.9
GT16RF	GT16RF EX	17000	21500	24000	1103	247	1764	396	2198	493	120	4.2	200	7.0	290	10.2
GT25RF	GT25RF EX	12000	15500	17000	1784	400	2977	667	3581	803	185	6.6	325	11.4	455	15.9

GTS-RF available to special order only- no Mounting Plate, lower frequency than GTRF model

GT10S-RF	GT10S-RF EX	17000	23000	25000	650	146	1350	303	1950	438	46	1.6	80	2.8	112	3.9
GT16S-RF	GT16S-RF EX	11500	15500	17000	1100	248	1900	427	2700	607	120	4.2	200	7.0	290	10.2
GT25S-RF	GT25S-RF EX	8500	11000	13000	2250	506	3600	809	4900	1102	185	6.5	325	11.4	455	16.1

Data obtained on a heavy laboratory test block. Frequency and force will decrease on a less rigid mounting while the noise level will increase.

* For UK Specification see leaflet GTSS L1003

VIBTEC AUSTRALIA

Unit 2, 64 Baile Road, Canning Vale, WA 6155, Perth Australia

Tel: +61 (0)8 6559 7470 Email: info@vibtec.com.au Web: www.vibtec.com.au

GT/RF STAINLESS STEEL PNEUMATIC TURBINE VIBRATORS (European Specification*)

DIMENSIONS

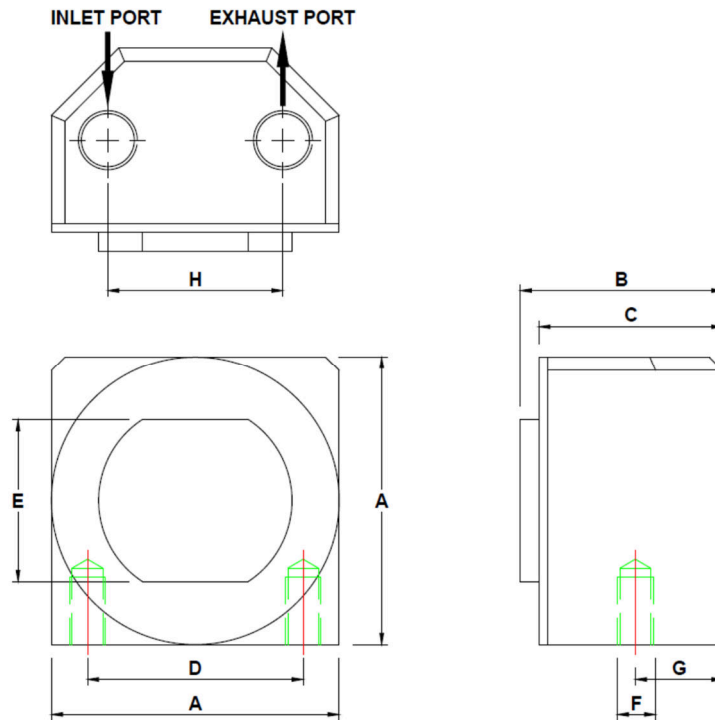

Drawing Number 0760

GTRF (EX) & GTS-RF (EX) Model

Model	A mm	B mm	C mm	D mm	E mm	F mm	G mm	Inlet Port	Ex Port	Weight Kgs
GT10RF & GT10S-RF	49	38	32	36	27	M6	16.0	1/8" BSP	1/8" BSP	0.625
GT16RF & GT16S-RF	64	45	39	48	36	M8	19.5	1/4" BSP	1/4" BSP	1.307
GT25RF & GT25-RF	78	55	49	60	50	M10	25.5	1/4" BSP	1/4" BSP	2.284

* For UK Specification see leaflet GTSS L1003

<p>Drawing 076011</p>	<p>We can also supply all these items:</p>			
<p>For Technical Advice on Filters, Hoses and Regulators ask for Technical Manual TM1390.</p>	<p>Filter Regulators and Lubricators Leaflet L1100</p>	<p>Exhausts & Fittings Leaflet L1102</p>	<p>3/2 Pneumatic Valves Leaflet L1103</p>	<p>3/2 Pneumatic Solenoid Valves Leaflet L1104</p>

VIBTEC AUSTRALIA

Unit 2, 64 Baile Road, Canning Vale, WA 6155, Perth Australia

Tel: +61 (0)8 6559 7470 Email: info@vibtec.com.au Web: www.vibtec.com.au